

1. Which of the following formulae for oscillatory motion is wrong on dimensional grounds? (y = displacement, a = amplitude, t = time, T = period, ν = frequency, ω = angular frequency, λ = wavelength)
- A) $y = 2a \cos [2\pi (\frac{t}{T} - \frac{x}{\lambda})]$ B) $y = a \cos (2\pi \nu t)$
- C) $y = \frac{a}{\sqrt{3}} (\cos \omega t + \sin \omega t)$ D) $y = \frac{a}{\lambda} \sin (2\pi \frac{t}{T})$
2. Which of the following vectors is parallel to the resultant of $\vec{A} = 2\hat{i} - 4\hat{j} + \hat{k}$ and $\vec{B} = \hat{i} + \hat{j} - 2\hat{k}$?
- A) $3\hat{i} - 3\hat{j} - 2\hat{k}$ B) $6\hat{i} - 6\hat{j} - 2\hat{k}$
- C) $\hat{i} - \hat{j} + \hat{k}$ D) $6\hat{i} - 6\hat{j} + 2\hat{k}$
3. Which of the following is a solution of the Laplace's equation $\nabla^2 u = 0$?
- A) $u = \frac{1}{r}$ B) $u = r^2$
- C) $u = x^2 y^2 + z^2$ D) $u = r^2 \sin \theta + \cos \phi$
4. If \vec{A} and \vec{B} are irrotational, $\vec{A} \times \vec{B}$ is
- A) irrotational B) solenoidal
- C) irrotational and solenoidal D) neither irrotational nor solenoidal
5. The eigen values of the matrix $\begin{pmatrix} 0 & -i \\ i & 0 \end{pmatrix}$ are
- A) (1, 1) B) (1, -1) C) (1, 0) D) (0, 0)
6. The number of independent components of a symmetric second rank tensor in 4 -dimensions is
- A) 16 B) 12 C) 10 D) 8
7. Which of the following graphs represents the solution of the differential equation $\frac{dy}{dx} = -ky$ where k is a positive constant?

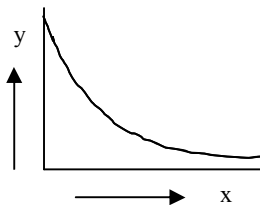

(A)

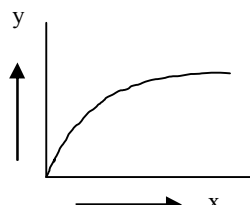

(B)

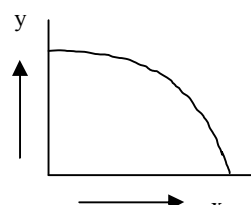

(C)

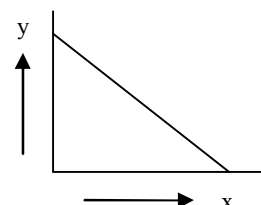

(D)

8. If the function $f(x) = x^4$ is expanded as a Fourier series in the interval $[-\pi, \pi]$, the first term of the series is
- A) $\frac{\pi^2}{3}$ B) $\frac{\pi^4}{5}$ C) $\frac{2\pi^2}{3}$ D) $\frac{2\pi^4}{5}$
9. The Laplace transform of $f(t) = e^{at}$ for $s > a$ is given by $F(s) =$
- A) $\frac{1}{s}$ B) $\frac{1}{a}$ C) $\frac{1}{s-a}$ D) $\frac{1}{s+a}$
10. The value of the integral $\int_0^{\infty} [\sin(3x) + 4]\delta\left(x - \frac{\pi}{2}\right) dx =$
- A) 0 B) 7 C) 4 D) 3
11. The derivative of a function $f(z)$ of a complex variable z governs
- A) the local behaviour of $f(z)$
 B) the distant behaviour of $f(z)$
 C) not only the local behaviour but also the distant behaviour of $f(z)$
 D) neither the local nor the distant behaviour of $f(z)$
12. The value of the integral $I = \oint_C \frac{dz}{(z-3)}$ where C is the circle $|z| = 4$ is
- A) 0 B) $2\pi i$ C) $4\pi i$ D) $8\pi i$
13. The generating function of Legendre polynomials $P_n(x)$ is
- A) $g(t, x) = (1 - 2xt + t^2)^{-1/2}, |t| < 1$
 B) $g(t, x) = (1 + 2xt + t^2)^{-1/2}, |t| < 1$
 C) $g(t, x) = (1 + 2xt + t^2)^{1/2}, |t| < 1$
 D) $g(t, x) = e^{-t^2+2tx}$
14. Sixty tickets are marked 1, 2, 3,, 60. From these, five tickets are picked at random and are given one each to five persons A, B, C, D and E. What is the probability that A gets the ticket with the largest number (among A, B, C, D and E) and B gets the ticket with the smallest number (among A, B, C, D and E)?
- A) $\frac{1}{5}$ B) $\frac{1}{20}$ C) $\frac{1}{60}$ D) $\frac{1}{9}$

15. The acceleration-time graph of a particle starting from rest at time $t = 0$ and moving along a straight line is shown in the diagram. The displacement of the particle from $t = 0$ to $t = 3\text{ s}$ is

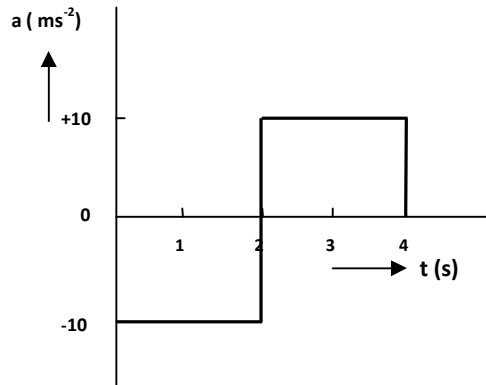

- A) -20 m B) -35 m C) -40 m D) $+35\text{ m}$
16. Two masses m and $2m$ are moving in the x - y plane with speeds u and $2u$ respectively as shown in the figure. They collide at P and stick together and move. Their common velocity after collision would be

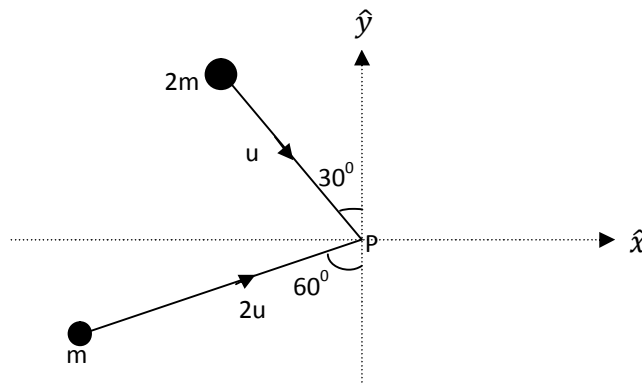

- A) $\frac{u}{3} [(1 + \sqrt{3}) \hat{x} + (1 - \sqrt{3}) \hat{y}]$ B) $\frac{u}{3} [(\sqrt{3} - 1) \hat{x} + (1 + \sqrt{3}) \hat{y}]$
 C) $\frac{u}{3} [(1 - \sqrt{3}) \hat{x} + (1 + \sqrt{3}) \hat{y}]$ D) $\frac{u}{3} [(1 - \sqrt{3}) \hat{x} + (\sqrt{3} - 1) \hat{y}]$
17. Two bodies of masses m and $3m$ are connected by a spring of spring constant k . The frequency of the normal mode is

- A) $\sqrt{\frac{3k}{4m}}$ B) $\sqrt{\frac{m}{k}}$ C) $\sqrt{\frac{k}{4m}}$ D) $\sqrt{\frac{4k}{3m}}$

18. Forces 10 N, 20 N and F act along the sides of an equilateral triangle PQR of side 5 cm as shown in the figure. C is the centroid of the triangle. What is the value of F in order that the net torque about C is zero?

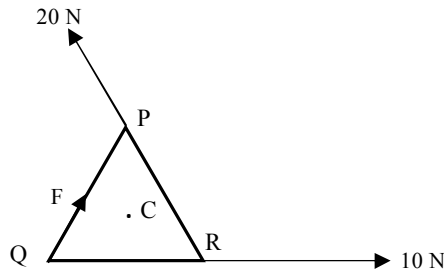

- A) 15 N B) 30 N C) 10 N D) 60 N
19. An observer in a spacecraft moving at $0.8c$ relative to the earth finds that a train takes 20 minutes to run from station A to station B. The corresponding time as measured by the driver of the train is
- A) 20 minutes B) 33.3 minutes
C) 12 minutes D) 16 minutes
20. A particle is placed in a region where the potential is $V(x) = \frac{1}{2}kx^2 + \frac{1}{3}\lambda x^3$ where $k > 0$ and $\lambda > 0$. Then
- A) $x = 0$ and $x = -\frac{k}{\lambda}$ are points of stable equilibrium
B) $x = 0$ and $x = -\frac{k}{\lambda}$ are points of unstable equilibrium
C) $x = 0$ is a point of stable equilibrium and $x = -\frac{k}{\lambda}$ is a point of unstable equilibrium
D) $x = 0$ is a point of unstable equilibrium and $x = -\frac{k}{\lambda}$ is a point of stable equilibrium
21. Group A contains some important discoveries in Physics. Group B contains the years of these discoveries. Match the discoveries with the year of discoveries.
- | Group A | Group B |
|-------------------------------------------|----------------|
| a. Quantum physics | (i) 1895 |
| b. X- rays | (ii) 1928 |
| c. Quantum theory of photoelectric effect | (iii) 1900 |
| d. Raman effect. | (iv) 1905 |
- A) a → iii, b → i, c → iv, d → ii
B) a → iv, b → i, c → ii, d → iii
C) a → ii, b → iii, c → iv, d → i
D) a → i, b → ii, c → iv, d → iii

22. The Lagrangian of a particle of mass m , attached to a fixed point O by a weightless inextensible string of length, l and rotating in a horizontal plane under gravity as shown in the figure is given by $L = \frac{1}{2} ml^2 (\dot{\theta}^2 + \sin^2\theta \dot{\phi}^2) - mgl\cos\theta$. The Hamiltonian of the particle is given by

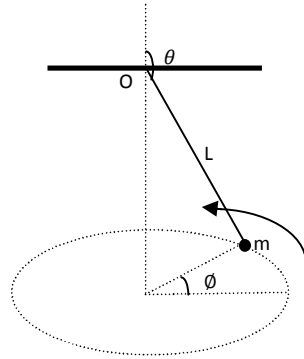

- A) $H = \frac{1}{2ml^2} \left(p_\theta^2 + \frac{p_\phi^2}{\sin^2\theta} \right) + mgl\cos\theta$
 B) $H = \frac{1}{2ml^2} \left(p_\theta^2 + \frac{p_\phi^2}{\sin^2\theta} \right) - mgl\cos\theta$
 C) $H = \frac{1}{2ml^2} (p_\theta^2 + p_\phi^2) + mgl\cos\theta$
 D) $H = \frac{1}{2ml^2} (p_\theta^2 + p_\phi^2) - mgl\cos\theta$
23. Which of the following statements is WRONG regarding phase space of a dynamical system?
 A) For a system with n degrees of freedom, the phase space is $2n$ - dimensional
 B) The distribution function is constant along any trajectory in phase space
 C) The phase space trajectories of a system can intersect each other
 D) The phase curves of a simple pendulum for small amplitudes are ellipses
24. For a system with one degree of freedom, the unit of phase volume is
 A) m^3 B) m^2 C) $J s$ D) $J s^{-1}$
25. Which of the following statements is CORRECT regarding motion under central forces?
 A) Linear momentum is conserved B) Angular momentum is conserved
 C) Orbits are always elliptical D) Total energy is always negative
26. Identify the CORRECT statement:
 A) In cyclones, high speed winds circulate around a high pressure region
 B) The wind direction in cyclones is clockwise in both hemispheres
 C) The wind direction in cyclones is clockwise in southern hemisphere and anticlockwise in northern hemisphere
 D) The wind direction in cyclones is anticlockwise in southern hemisphere and clockwise in northern hemisphere

27. What should be the velocity of a neutron (mass = 1.67×10^{-27} kg) in order that its de Broglie wavelength is 0.28 nm?
 A) 2.37 m s^{-1} B) 1.42 km s^{-1} C) 1.42 m s^{-1} D) 2.37 km s^{-1}
28. The wave function of a particle constrained to move along the x-axis with $0 \leq x \leq L$ is given by $\psi(x) = \sqrt{\frac{2}{L}} \sin\left(\frac{n\pi x}{L}\right)$, n being an integer. The expectation value of its momentum will be
 A) $\frac{n\pi\hbar}{L^2}$ B) $\left(\frac{n\pi\hbar}{L}\right)^2$ C) $\frac{n^2\pi}{L^2}$ D) 0
29. Which of the following relations is CORRECT?
 A) $[\hat{p}, \hat{x}] = i\hbar$ B) $[\hat{p}, \hat{x}] = \frac{\hbar}{i}$
 C) $[\hat{p}, \hat{x}] = \frac{1}{i\hbar}$ D) $[\hat{p}, \hat{x}] = -\frac{1}{i\hbar}$
30. A proton and an electron with the same energy E approach a potential barrier whose height is greater than E . Then the probability of penetration through the barrier is
 A) higher for the proton than for the electron
 B) smaller for the proton than for the electron
 C) same for the proton and the electron
 D) 1836 times higher for the proton than for the electron
31. A particle is moving in a potential $V(x) = \frac{1}{2}m\omega^2 x^2$
 The energy eigen values of the particle are (n is an integer)
 A) $E_n = \left(2n + \frac{3}{2}\right)\hbar\omega$ B) $E_n = \left(n + \frac{1}{2}\right)\hbar\omega$
 C) $E_n = \left(2n + \frac{1}{2}\right)\hbar\omega$ D) $E_n = n\hbar\omega$
32. The commutator $[p^2, x^2] =$
 A) $-2i\hbar xp$ B) $-2i\hbar px$
 C) $-2i\hbar (xp + px)$ D) $2i\hbar (xp - px)$
33. A particle of mass m is subjected to a potential $V(x) = \begin{cases} -V_0 & \text{for } 0 < x < L \\ 0 & \text{for } x < 0 \text{ and } x > L \end{cases}$
 In order that there is at least one bound state,
 A) $V_0 \geq \frac{\hbar^2 \pi^2}{2mL^2}$ B) $V_0 \geq \frac{\hbar^2 \pi^2}{4mL^2}$ C) $V_0 < \frac{\hbar^2 \pi^2}{2mL^2}$ D) $V_0 \geq \frac{8 \hbar^2 \pi^2}{mL^2}$

34. The vectors $|n\rangle$, $n = 1, 2, 3, \dots$ constitute a complete orthonormal basis. Then which of the following statements is WRONG?
- A) Any arbitrary vector $|\alpha\rangle$ can be expanded as $|\alpha\rangle = \sum_n C_n |n\rangle$
 B) Any arbitrary vector $|\alpha\rangle$ can be written as $|\alpha\rangle = \sum_n \langle n|\alpha\rangle |n\rangle$
 C) $\sum_n |n\rangle\langle n| = I$, the identity operator
 D) $\langle m|n\rangle = \delta_{mn}$
35. The ground state wave function of hydrogen atom is $\psi = \frac{e^{-r/a_0}}{\sqrt{\pi a_0^3}}$, then the expectation value of $\frac{1}{r}$ in this state is
- A) a_0 B) 1 C) $1/a_0$ D) a_0^2
36. A particle is in the simultaneous eigen state $|l, m\rangle$ of the orbital angular momentum operators L^2 and L_z with eigen values $l(l+1)\hbar^2$ and $m\hbar$ respectively. Then the expectation value of L_y^2 of the particle in this state satisfies
- A) $0 \leq \langle L_y^2 \rangle \leq l^2 \hbar^2$
 B) $0 \leq \langle L_y^2 \rangle \leq \frac{1}{2} l(l+1) \hbar^2$
 C) $\frac{1}{2} m^2 \hbar^2 \leq \langle L_y^2 \rangle \leq \frac{1}{2} l(l+1) \hbar^2$
 D) $\langle L_y^2 \rangle = 0$
37. Which of the following statements is TRUE for Heisenberg picture of quantum dynamics?
- A) Both operators and state vectors change with time
 B) The operator that effects time translation of state kets is $e^{-\frac{\hat{H}t}{\hbar}}$
 C) Operators do not change with time
 D) Operators change with time according to the relation $\frac{d\hat{A}}{dt} = \frac{1}{i\hbar} [\hat{A}, \hat{H}]$
38. Group A contains some important theories in Physics. Group B contains the names of the scientists who proposed these theories. Match the discoveries with the name of the scientist who proposed the theories.
- | Group A | | Group B | |
|----------------|------------------------------|----------------|-----------------|
| a. | Topological phase transition | i | Murray Gell-Man |
| b. | Big bang nucleosynthesis. | ii | D. J. Thouless |
| c. | Black hole radiation | iii | George Gamow |
| d. | Quarks structure of hadrons | iv | Stephen Hawking |
- A) a \rightarrow i, b \rightarrow iii, c \rightarrow iv, d \rightarrow ii B) a \rightarrow ii, b \rightarrow iii, c \rightarrow iv, d \rightarrow i
 C) a \rightarrow i, b \rightarrow iv, c \rightarrow ii, d \rightarrow iii D) a \rightarrow iii, b \rightarrow iv, c \rightarrow i, d \rightarrow ii

39. Fermi's golden rule is NOT concerned with
 A) harmonic perturbation
 B) transition probability
 C) time independent perturbation
 D) molecular systems
40. In an elastic scattering of particles in $l = 0$ state, the incident wave vector is of magnitude $\sqrt{\pi} \text{ fm}^{-1}$ and the phase shift is 90° . The total scattering cross section is
 A) 0.04 barn B) 0.4 barn C) 4 barn D) 400 barn
41. An ideal diatomic gas is subjected to three successive reversible processes and figure shows the corresponding P-V diagram. AB represents an adiabatic expansion and CA represents an isothermal compression. Then which of the following statements is TRUE regarding entropy changes?

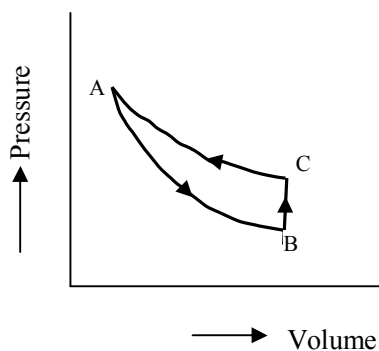

- A) The entropy of the gas remains constant during each of the processes
 B) The entropy of the surroundings remains constant during each of the processes
 C) The combined entropy of the gas and the surroundings remains constant during each of the processes
 D) For the complete cycle, the combined entropy of the gas and the surroundings increases.
42. Which of the following sets of Maxwell's thermodynamic relations is WRONG? (U- internal energy, H- enthalpy, G- Gibbs free energy, F- Helmholtz free energy)
- A) $T = \left(\frac{\partial U}{\partial S}\right)_V$; $P = -\left(\frac{\partial U}{\partial V}\right)_S$ B) $T = \left(\frac{\partial H}{\partial S}\right)_V$; $V = -\left(\frac{\partial H}{\partial P}\right)_S$
 C) $S = -\left(\frac{\partial F}{\partial T}\right)_V$; $P = -\left(\frac{\partial F}{\partial V}\right)_T$ D) $S = -\left(\frac{\partial G}{\partial T}\right)_P$; $V = \left(\frac{\partial G}{\partial P}\right)_T$
43. An ideal gas is having a volume V_0 at temperature T. Its isothermal compressibility (κ) is given by
 A) $-\frac{1}{V_0} \left(\frac{\partial V}{\partial P}\right)_T$ B) $\frac{1}{V_0} \left(\frac{\partial V}{\partial P}\right)_T$ C) $-V_0 \left(\frac{\partial P}{\partial V}\right)_T$ D) $V_0 \left(\frac{\partial P}{\partial V}\right)_T$

44. A system has four energy levels with energies $0, \epsilon, 2\epsilon$ and 3ϵ . Of these, the levels ϵ and 2ϵ are three-fold degenerate and the other two levels are non-degenerate. The partition function of the system with $\beta = \frac{1}{k_B T}$ is given by
- A) $1 + e^{-3\beta\epsilon}$ B) $3(e^{-\beta\epsilon} + e^{-2\beta\epsilon})$
 C) $1 + e^{-\beta\epsilon} + e^{-2\beta\epsilon} + e^{-3\beta\epsilon}$ D) $(1 + e^{-\beta\epsilon})^3$
45. Two identical systems at the same temperature and each having the initial entropy S are placed in thermal contact. The entropy of the combined system will be
- A) S^2 B) $2S$ C) $\frac{1}{2}S$ D) $S \ln 2$
46. Two spherical black bodies A and B of radii R and $3R$ are kept at temperatures $2T$ and T respectively. The ratio of the total power emitted by them is given by $\frac{P_A}{P_B} =$
- A) $\frac{4}{81}$ B) $\frac{81}{4}$ C) $\frac{16}{9}$ D) $\frac{9}{16}$
47. The brightest part of the spectrum of a certain star is located at a wavelength of 290 nm . The surface temperature of the star is
- A) 10^6 K B) 10^4 K C) 10^5 K D) 10^7 K
48. In the case of Maxwellian distribution of velocity of the molecules of an ideal gas, the ratio of the r.m.s. velocity to the most probable velocity is
- A) $\frac{3}{2}$ B) $\sqrt{\frac{2}{3}}$ C) $\sqrt{\frac{8}{3}}$ D) $\sqrt{\frac{3}{2}}$
49. Which of the following will obey Fermi-Dirac statistics?
- A) liquid He^3 B) photons C) Cooper pairs D) liquid He^4
50. Bose-Einstein condensation occurs in liquid He^4 kept under suitable pressure at 2.17 K . What is the temperature at which a sample of He^4 in gaseous state will undergo Bose-Einstein condensation? Assume that it is a perfect Bose gas and the particle density in the gaseous state is 1000 times smaller than that in the liquid state.
- A) 2.17 K B) 2.17 mK C) 21.7 mK D) 21.7 K
51. Figure shows two equipotential lines associated with a uniform electric field existing in the x - y plane. The x - and y -components E_x and E_y of the field in the region between the lines are

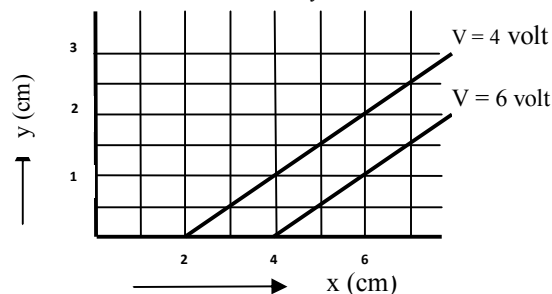

- A) $E_x = -100 \text{ Vm}^{-1}, E_y = +200 \text{ Vm}^{-1}$
 B) $E_x = +100 \text{ Vm}^{-1}, E_y = -200 \text{ Vm}^{-1}$
 C) $E_x = +200 \text{ Vm}^{-1}, E_y = +100 \text{ Vm}^{-1}$
 D) $E_x = -200 \text{ Vm}^{-1}, E_y = -100 \text{ Vm}^{-1}$

52. The frequency of revolution of charged particles in a cyclotron is independent of the
- A) mass of the particle B) charge of the particle
 C) speed of the particle D) strength of the magnetic field

53. In the figure shown below, a current of 2.1 A enters the bridge circuit. The current in the 8 Ω resistor is

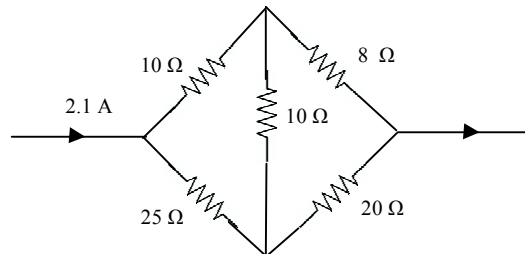

- A) 2.1 A B) 1.5 A C) 0.6 A D) 0.84 A

54. In a certain region, there exists a uniform electric field and a uniform magnetic field in the same direction. A electron is projected into this region with a velocity in the same direction as the fields. Inside the region,

- A) the electron will deflect to its left
 B) the electron will deflect to its right
 C) the speed of the electron will increase
 D) the speed of the electron will decrease

55. The capacitor shown in the circuit is fully charged initially. After closing the switch S, the time taken for the energy stored in the capacitor to get reduced to half its initial value is

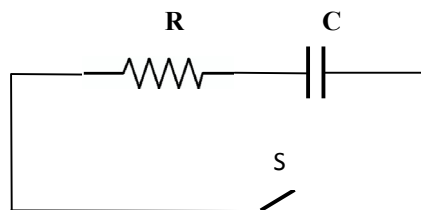

- A) $2RC \ln 2$ B) $\frac{1}{2}RC \ln 2$ C) $\frac{1}{2RC} \ln 2$ D) $RC \ln 2$

56. The law which enables to calculate the magnetic field at any point in the region around a current carrying conductor is

- A) Gauss's law B) Biot-Savart law
 C) Faraday's law D) Lenz's law

57. The magnetic field of a plane electromagnetic wave is given by

$\vec{B}(x, y, z, t) = \hat{k} B_0 \sin \left[\frac{k}{\sqrt{2}}(x + y) + \omega t \right]$ where k is the wave number and $\hat{i}, \hat{j}, \hat{k}$ are the unit vectors along the x, y and z -directions. The electric field associated with the wave is given by

- A) $\vec{E}(x, y, z, t) = \hat{i} c B_0 \sin \left[\frac{k}{\sqrt{2}}(x + y) + \omega t \right]$
 B) $\vec{E}(x, y, z, t) = \hat{j} c B_0 \sin \left[\frac{k}{\sqrt{2}}(x + y) + \omega t \right]$
 C) $\vec{E}(x, y, z, t) = \frac{(i - j)}{\sqrt{2}} c B_0 \sin \left[\frac{k}{\sqrt{2}}(x + y) + \omega t \right]$
 D) $\vec{E}(x, y, z, t) = \frac{(i + j)}{\sqrt{2}} c B_0 \sin \left[\frac{k}{\sqrt{2}}(x + y) + \omega t \right]$

58. Group A contains some important discoveries in Physics. Group B contains the names of the scientists who made these discoveries. Match the discoveries with the name(s) of the scientists who discovered it.

- | Group A | Group B |
|----------------|-------------------------------------|
| a) Transistors | (i) J. Chadwick |
| b) LASER | (ii) A. Penzias and R. Wilson |
| c) CMBR | (iii) Theodore H. Maiman |
| d) Neutron | (iv) Shockley, Bardeen and Brattain |

- A) a → ii, b → iv, c → i, d → iii B) a → iii, b → ii, c → i, d → iv
 C) a → iv, b → iii, c → ii, d → i D) a → iii, b → i, c → ii, d → iv

59. Corresponding to the equation $\vec{D} = \epsilon_0 \vec{E} + \vec{P}$ in electrostatics, the equation valid in magnetic case is

- A) $\vec{B} = \mu_0 \vec{H} + \vec{M}$ B) $\vec{H} = \frac{1}{\mu_0} \vec{B} - \vec{M}$
 C) $\vec{B} = \mu_0 \vec{H} - \vec{M}$ D) $\vec{B} = \mu_0 \vec{M} + \vec{H}$

60. In a Michelson interferometer arrangement, when one of the mirrors is moved by a distance of 0.08mm, 250 fringes cross the field of view. The wavelength of the source is

- A) 640 Å B) 3200 Å C) 6400 mm D) 6400 Å

61. The total power radiated by an oscillating electric dipole is

- A) inversely proportional to the dipole moment
 B) inversely proportional to the frequency of oscillation
 C) directly proportional to the fourth power of the frequency of oscillation
 D) independent of the frequency of oscillation

62. A right circularly polarised light beam is incident normally on a calcite half-wave plate. Then the emergent beam is

- A) right circularly polarised B) left circularly polarised
 C) right elliptically polarised D) left elliptically polarised

63. When a plane electromagnetic wave propagates through a dielectric, the direction of energy flow is that of
 A) $\vec{k} \times \vec{H}$ B) $\vec{k} \times \vec{E}$ C) $\vec{E} \times \vec{H}$ D) $\vec{H} \times \vec{E}$
64. Two harmonic waves having the same frequency, but with displacements in mutually perpendicular directions are represented by $x = x_0 \sin(\omega t - kz)$ and $y = y_0 \sin(\omega t - kz + \varphi)$. These two together can constitute a plane polarised wave if $\varphi =$
 A) $\frac{3}{2}\pi$ B) $\frac{1}{2}\pi$ C) $\frac{1}{4}\pi$ D) 0
65. 10 KeV photons belong to
 A) microwaves B) infra red rays
 C) ultra violet rays D) X-rays
66. The electron configuration of an excited state of nitrogen atom is $1s^2 2s^2 2p^2 3d^1$. The degeneracy of the state is
 A) 10 B) 15 C) 6 D) 5
67. The intensity ratio of D_1 ($\lambda = 589.6$ nm) and D_2 ($\lambda = 589.0$ nm) lines of Sodium at high temperature is
 A) 3:1 B) 1:2 C) 1:1 D) 3:2
68. An atom undergoes a transition from a state whose life time is 1 nanosecond and emits radiation. The natural line width of the spectral line emitted is of the order of
 A) 10^{-10} eV B) 10^{-8} eV C) 10^{-6} eV D) 10^{-3} eV
69. The minimum magnetic field required for the normal Zeeman splitting of a spectral line of wavelength 500 nm to be observed with a spectrometer having a resolution of 0.01 nm is
 A) 0.857 T B) 1.34 T C) 0.26 T D) 0.587 T
70. The number of spectral terms resulting from the j-j coupling of a 3p electron and a 3d electron is
 A) 15 B) 12 C) 10 D) 9
71. A diatomic molecule undergoes a vibrational-rotational transition in which the vibrational and rotational quantum numbers of the initial and final states are restricted to $v \leq 1$ and $J \leq 2$ and subject to the selection rules $\Delta v = \pm 1$; $\Delta J = 0, \pm 1$. Among the allowed transitions, the energy involved is largest for
 A) $(v, J) = (0, 0) \rightarrow (1, 0)$ B) $(v, J) = (0, 0) \rightarrow (1, 1)$
 C) $(v, J) = (0, 1) \rightarrow (1, 1)$ D) $(v, J) = (0, 1) \rightarrow (1, 2)$
72. The number of normal modes of vibration possible for C_6H_6 molecule is
 A) 6 B) 12 C) 31 D) 30
73. Which of the following molecules DOES NOT have a microwave spectrum?
 A) BCl_3 B) CH_4 C) CH_3F D) OCS

74. A He-Ne laser cavity consists of two mirrors of reflectivities 1 and 0.98, separated by a distance of 30 cm. The medium between the mirrors has refractive index = 1 and absorption coefficient = 0. The separation between the longitudinal modes of the cavity is
 A) 750 MHz B) 500 MHz C) 250 MHz D) 750 kHz
75. Which of the following nuclei DOES NOT possess NMR spectrum?
 A) ^{10}B B) ^{14}N C) ^4He D) ^{13}C
76. The rotational constant of CO_2 molecule is B. Then the line-spacing in the P and R branches of the IR spectrum of $^{16}\text{O} - ^{12}\text{C} - ^{16}\text{O}$ molecule and $^{18}\text{O} - ^{12}\text{C} - ^{16}\text{O}$ molecule are respectively
 A) 2B and 2B B) 2B and 4B C) 4B and 2B D) 2B and B
77. The spectrum which enables the determination of moment of inertia and bond force constant of N_2 molecule is
 A) electronic spectrum B) infra red spectrum
 C) microwave spectrum D) ESR spectrum
78. Which of the following statements is TRUE regarding fluorescence?
 A) The radiation emitted by the molecule has the same frequency as the radiation which is initially absorbed
 B) The radiation emitted by the molecule contains both higher and lower frequencies as compared to the frequency of the absorbed radiation
 C) The radiation emitted by the molecule is of lower frequency as compared to the absorbed radiation
 D) The emission takes place with a time delay of minutes or even hours after the initial absorption
79. Example of mirror nuclei is
 A) $^{14}\text{N}_7$ and $^{13}\text{N}_7$ B) $^{13}\text{N}_7$ and $^{13}\text{C}_6$
 C) $^{12}\text{C}_6$ and $^{13}\text{C}_6$ D) $^{13}\text{N}_7$ and $^{12}\text{C}_6$
80. Group A contains elementary excitations/bosons. Group B contains the associated field/interactions. Match these excitations/bosons with the fields/interactions.
- | Group A | | Group B | |
|----------------|-------|----------------------------|--|
| a. Phonons | (i) | spin waves. | |
| b. Plasmons | (ii) | mediate strong interaction | |
| c. Magnons | (iii) | lattice vibrations | |
| d. Gluons | (iv) | plasma oscillations | |
- A) a → iii, b → iv, c → i, d → ii B) a → iv, b → iii, c → ii, d → i
 C) a → iii, b → i, c → iv, d → ii D) a → ii, b → iii, c → iv, d → i
81. Nucleon-nucleon interaction is
 A) charge dependent B) spin independent
 C) charge independent D) charge asymmetric

82. Which one of the following reactions can occur
 A) $\Lambda^0 \rightarrow \pi^+ + \pi^-$
 B) $\pi^- + p \rightarrow n + \pi^0$
 C) $\pi^+ + p \rightarrow \pi^+ + p + \pi^- + \pi^0$
 D) $\gamma + n \rightarrow \pi^+ + p$
83. The significance of Co⁶⁰ experiment is that it supports
 A) energy conservation in alpha decay
 B) upholds the law of conservation of parity in beta decay
 C) charge conservation in elementary particle interaction
 D) breakdown of the conservation of parity in beta decay
84. Which one of the following is used as moderator in a nuclear reactor
 A) Heavy water
 B) Diamond
 C) U²³³
 D) Liquid metal
85. The binding energy of the neon isotope ${}_{10}\text{Ne}^{20}$ is 160.65 MeV, and then its atomic mass is
 A) 19.99u
 B) 29.99u
 C) 9.99u
 D) 23.99u
86. The minimum energy of a photon required for pair production of an electron and a positron is
 A) 2.04 MeV
 B) 1.02 keV
 C) 1.02 eV
 D) 1.02 MeV
87. Pauli proposed the existence of neutrinos to:
 A) explain conservation of energy in alpha decay.
 B) explain parity violation in beta decay
 C) explain conservation of energy in beta decay.
 D) explain conservation of strangeness in beta decay.
88. Geiger-Nuttall rule expresses a relationship between
 A) the logarithm of the disintegration constant and that of decay energy
 B) the disintegration constant and square of the decay energy
 C) the disintegration constant and the number of atoms
 D) the parent nuclei and the daughter nuclei.
89. The quark structure of proton is
 A) udd
 B) uud
 C) us
 D) $u\bar{d}$
90. Identify the missing element in the following reaction:
 ${}^3_1\text{H} + {}^1_1\text{H} \rightarrow ? + {}^1_0\text{n}$
 A) ${}^3_1\text{H}$
 B) ${}^4_2\text{He}$
 C) ${}^3_2\text{He}$
 D) ${}^1_0\text{n}$
91. Neutrino oscillation implies
 A) neutron decay
 B) that neutrinos are mass less
 C) proton decay
 D) existence of a non zero value for the mass of the neutrinos

92. As per Fermi-Dirac distribution, what is the probability of occupation of electron at the Fermi level at a finite temperature?
 A) 70.71 % B) 0.5 % C) 50 % D) 100 %
93. Consider a superconducting ring placed in a magnetic field, then
 A) no magnetic field exists inside the ring
 B) no remarkable property happens
 C) magnetic field does not exist outside the ring
 D) the magnetic flux that passes through the ring gets quantized
94. Choose the correct statement
 A) A superconductor does not show diamagnetic properties
 B) To destroy Type I superconductivity a large magnetic field is required
 C) At the transition from normal state to a superconducting state specific heat of the specimen continuously changes
 D) Type II superconductors find more practical applications than Type I
95. Hall resistance is given by
 A) $\rho_H = \frac{E_y}{j_x}$ B) $\rho_H = \frac{E_y}{j_y}$ C) $\rho_H = E_y j_x$ D) $R_H = \frac{E_y}{j_x B}$
96. The space lattice of NaCl crystal is
 A) hexagonal B) fcc C) sc D) bcc
97. If d is the interplanar spacing, Bragg reflection can occur only for wavelength λ
 A) $\geq 2d$ B) $\leq d$ C) $\leq 2d$ D) $= d/2$
98. Choose the correct statement:
 A) A colour centre is a lattice defect which emits visible light
 B) A colour centre is a lattice defect which absorbs visible light
 C) A colour centre is a lattice defect which emits infrared light
 D) A colour centre is a lattice defect which absorbs phonons
99. Weidemann-Franz law says that, if K is thermal conductivity and σ is the electrical conductivity, T the temperature then
 A) $\frac{K}{\sigma T}$ is the same for all metals
 B) $K \sigma$ is the same for all metals
 C) $\frac{K}{\sigma T^2}$ is the same for all metals
 D) $K \sigma T$ is the same for all metals
100. Choose the correct statement:
 A) Only ferroelectric crystals show piezoelectric effect
 B) Ferroelectric crystals do not show piezoelectric effect
 C) Ferroelectric crystals exhibit dipole moment only in the presence of an external electric field
 D) A crystal may be piezoelectric without being ferroelectric.

101. Group A contains some important theories/observations in Physics. Group B contains the names of the scientists who predicted these theories/made observations. Match the discoveries with the name of the scientists who discovered it.

Group A		Group B	
a.	Dark matter	i)	A Einstein
b.	Gravitational waves	ii)	Klaus von Klitizing
c.	Liquid helium	iii)	F. Zwicky
d.	Quantum Hall Effect	iv)	H K Onnes
A) a → iii, b → i, c → iv, d → ii		B) a → ii, b → iv, c → i, d → iii	
C) a → iv, b → iii, c → i, d → ii		D) a → iv, b → i, c → ii, d → iii	

102. If a is the primitive axis of the crystal lattice, the boundaries of the first Brillouin zone of a linear lattice lies at

A) $K = \pm \frac{2\pi}{a}$ B) $K = \pm \pi$ C) $K = \pm \frac{\pi}{a}$ D) $K = \pm \frac{\pi}{a^2}$

103. The Fermi energy of sodium is 3.2 eV. The Fermi velocity is (mass of electron is 9.11×10^{-31} kg)

A) 0.5×10^6 m/s B) 1.1×10^6 m/s C) 0.11×10^6 m/s D) 1.1×10^6 cm/s

104. Group A contains certain terms in Physics. Group B contains the topic/subject associated with these terms. Match the terms with the topic/subject

Group A		Group B	
a.	Chandrasekhar limit	i)	Superconductivity
b.	Cooper pairs	ii)	Bose-Einstein Condensation
c.	Joule – Thomson cooling	iii)	White dwarf
d.	Gross-Pitaevskii equation	iv)	Thermodynamics.
A) a → iii, b → i, c → iv, d → ii		B) a → ii, b → iv, c → i, d → iii	
C) a → iv, b → ii, c → i, d → iii		D) a → ii, b → i, c → iv, d → iii	

105. In the energy band diagram of silicon doped with arsenic, the Fermi level lies in the

- A) middle of the forbidden gap
 B) upper part of the forbidden gap
 C) lower part of the forbidden gap
 D) conduction band

106. Which of the following statements is TRUE regarding reverse saturation current (I_0) in diodes ?

- A) In a silicon diode, I_0 is normally larger by a factor of about 1000 than that in a germanium diode of comparable ratings
 B) For silicon diodes, I_0 is of the order of microamperes at room temperature
 C) I_0 increases with temperature for germanium diodes while I_0 decreases with temperature for silicon diodes
 D) I_0 increases with temperature for both silicon and germanium diodes

107. In the circuit shown below, the breakdown voltage of the Zener diode is 6 V. The load current and the Zener diode current are respectively given by

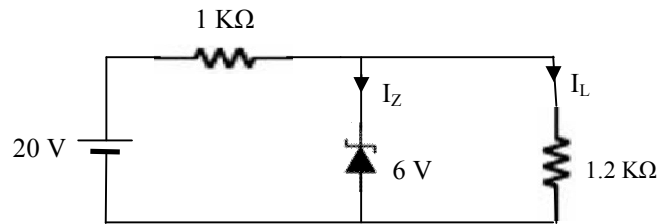

- A) $I_L = 0, I_Z = 9 \text{ mA}$ B) $I_L = 5 \text{ mA}, I_Z = 9 \text{ mA}$
 C) $I_L = 9 \text{ mA}, I_Z = 0$ D) $I_L = 14 \text{ mA}, I_Z = 9 \text{ mA}$
108. In the transistor biasing circuit shown below, $V_{BE} = 0.7 \text{ V}$. The collector to ground voltage is given by

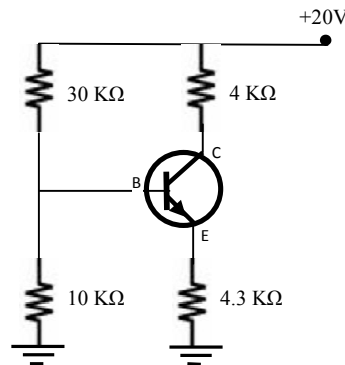

- A) 4 V B) 15 V C) 16 V D) 5 V
109. Which of the following statements is CORRECT for a common emitter amplifier circuit?
- A) Both $p-n$ junctions are forward biased
 B) The output is taken from the emitter
 C) The output voltage is in phase with the input voltage
 D) There is a phase difference of 180° between the input and output voltages
110. When an n-channel MOSFET is operated in the enhancement mode, the gate voltage is kept
- A) zero B) positive
 C) negative D) positive or negative
111. A phase shift oscillator has a feedback network consisting of three identical RC sections with $R = 100 \text{ k}\Omega$ and $C = 0.01 \text{ }\mu\text{F}$. The frequency of oscillations is
- A) 65 Hz B) 130 Hz C) 160 Hz D) 650 Hz

112. Which of the following statements regarding op amps is NOT CORRECT ?

- A) It uses direct coupling
- B) Input impedance is high
- C) Output impedance is high
- D) Voltage gain can be adjusted using external resistors

113. For the circuit with the input waveform shown below, the output waveform is

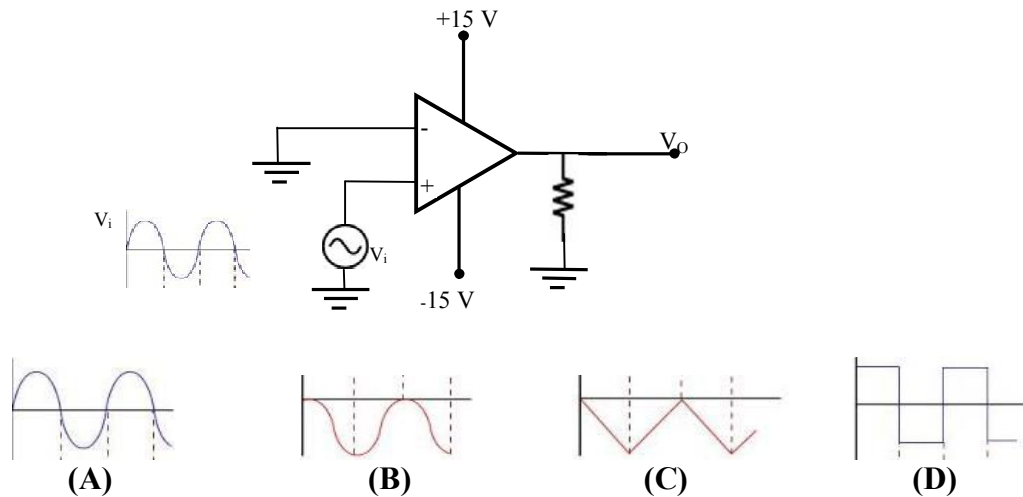

114. Semiconductors of interest for making visible LED must have energy band gaps

- A) larger than 3.0 eV
- B) larger than 1.8 eV
- C) less than 1.8 eV
- D) less than 0.3 eV

115. Which of the following DOES NOT represent an exclusive OR operation for inputs A and B?

- A) $(A + B)\overline{AB}$
- B) $(A + B)(\overline{A} + \overline{B})$
- C) $(A + B)AB$
- D) $(\overline{A}\overline{B} + \overline{B}A)$

116. The output of a 12-bit digital to analog converter (DAC) varies from -10 V to +10V. Its voltage resolution is

- A) 5 mV
- B) 40 mV
- C) 100 mV
- D) 1 mV

117. The minimum number of flip-flops needed to construct a mod-200 counter is

- A) 14
- B) 7
- C) 8
- D) 9

118. In the digital circuit shown in the figure, the input C is always kept high. The entries in the last column of its truth table from top to bottom are respectively

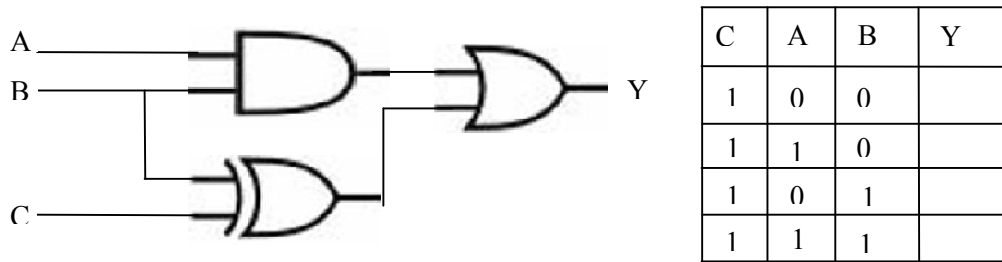

- A) 1 0 1 0 B) 1 1 0 1 C) 1 0 1 1 D) 1 1 1 1
119. In a microprocessor, which bus is bidirectional?
 A) Address bus B) Data bus
 C) Address bus and data bus D) Address bus and control bus
120. Unlike microprocessors, microcontrollers make use of batteries because they have
 A) low voltage consumption B) low current consumption
 C) low power consumption D) high power consumption
