

Test Booklet Code & Serial No.

प्रश्नपत्रिका कोड व क्रमांक
Paper-II

A

PHYSICAL SCIENCE

Signature and Name of Invigilator

Seat No.

1. (Signature)

(In figures as in Admit Card)

(Name)

Seat No.

(In words)

2. (Signature)

(Name)

OMR Sheet No.

(To be filled by the Candidate)

SEP - 32221

Time Allowed : 2 Hours]

[Maximum Marks : 200

Number of Pages in this Booklet : 24

Number of Questions in this Booklet : 100

Instructions for the Candidates

- Write your Seat No. and OMR Sheet No. in the space provided on the top of this page.
- This paper consists of **100** objective type questions. Each question will carry *two* marks. *All* questions of Paper II will be compulsory.
- At the commencement of examination, the question booklet will be given to the student. In the first 5 minutes, you are requested to open the booklet and compulsorily examine it as follows :
 - To have access to the Question Booklet, tear off the paper seal on the edge of this cover page. Do not accept a booklet without sticker-seal or open booklet.
 - Tally the number of pages and number of questions in the booklet with the information printed on the cover page. Faulty booklets due to missing pages/questions or questions repeated or not in serial order or any other discrepancy should not be accepted and correct booklet should be obtained from the invigilator within the period of 5 minutes. Afterwards, neither the Question Booklet will be replaced nor any extra time will be given. The same may please be noted.
 - After this verification is over, the OMR Sheet Number should be entered on this Test Booklet.
- Each question has four alternative responses marked (A), (B), (C) and (D). You have to darken the circle as indicated below on the correct response against each item.
Example : where (C) is the correct response.

(A)	(B)	(C)	(D)
-----	-----	-----	-----
- Your responses to the items are to be indicated in the **OMR Sheet given inside the Booklet only**. If you mark at any place other than in the circle in the OMR Sheet, it will not be evaluated.
- Read instructions given inside carefully.
- Rough Work is to be done at the end of this booklet.
- If you write your Name, Seat Number, Phone Number or put any mark on any part of the OMR Sheet, except for the space allotted for the relevant entries, which may disclose your identity, or use abusive language or employ any other unfair means, you will render yourself liable to disqualification.
- You have to return original OMR Sheet to the invigilator at the end of the examination compulsorily and must not carry it with you outside the Examination Hall. You are, however, allowed to carry the Test Booklet and duplicate copy of OMR Sheet on conclusion of examination.
- Use only Blue/Black Ball point pen.
- Use of any calculator or log table, etc., is prohibited.
- There is no negative marking for incorrect answers.

विद्यार्थ्यांसाठी महत्वाच्या सूचना

- परीक्षार्थींनी आपला आसन क्रमांक वा पुस्तकीतील काचव कोप्यात लिहावा. तसेच आपला दिलेल्या उत्तरपत्रिकेचा क्रमांक तपाशासाठी लिहावा.
- सदर प्रश्नपत्रिकेत 100 बहुपर्यायी प्रश्न आहेत. प्रत्येक प्रश्नास दोन गुण आहेत. या प्रश्नपत्रिकेतील सर्व प्रश्न सोडविणे अनिवार्य आहे.
- परीक्षा सुरु झाल्यावर विद्यार्थ्यांना प्रश्नपत्रिका दिली जाईल. सुरुवातीच्या 5 मिनीटांमध्ये आपण सदर प्रश्नपत्रिका उघडून खालील कधी अवश्य तपासून घ्याव्यात.
 - प्रश्नपत्रिका उघडण्यासाठी प्रश्नपत्रिकेवर लवलेले सील उघडावे. सील नसलेली किंवा सील उघडलेली प्रश्नपत्रिका स्विकारू नये.
 - पहिल्या पुस्तकावर तमूद केलेल्याप्रमाणे प्रश्नपत्रिकेची एकूण पुन्हे तसेच प्रश्नपत्रिकेतील एकूण प्रश्नांची संख्या पडतपडत पहावी. पुन्हे कमी असलेली/कमी प्रश्न असलेली/प्रश्नांचा चुकीचा क्रम असलेली किंवा इतर कुटी असलेली सदर प्रश्नपत्रिका सुरुवातीच्या 5 मिनिटांतच पर्यवेक्षणरता परत देऊन दुसरी प्रश्नपत्रिका मागवून घ्यावी. त्यानंतर प्रश्नपत्रिका बंदवून मिळयार नाही तसेच वेळो वेळ उघडून मिळयार नाही याची कुपचा विद्यार्थ्यांनी नोंद घ्यावी.
 - परीक्षेप्रमाणे सर्व पडताळून पाहिल्यानंतरच प्रश्नपत्रिकेवर ओ.एम.आर. उत्तरपत्रिकेचा नंबर लिहावा.
- प्रत्येक प्रश्नासाठी (A), (B), (C) आणि (D) अशी चार विकल्प उतर दिली आहेत. त्यातील योग्य उतराचा रकाना खाली दर्शविल्याप्रमाणे उळकवणे कायदाबंद करावा.
उदा. : जर (C) हे योग्य उत्तर असेल तर.

(A)	(B)	(C)	(D)
-----	-----	-----	-----
- या प्रश्नपत्रिकेतील प्रश्नांची उतर ओ.एम.आर. उत्तरपत्रिकेलाच दर्शवावीत. इतर ठिकाणी लिहिलेली उतर तपासली जाणार नाहीत.
- आत दिलेल्या सूचना काळजीपूर्वक वाचल्यात.
- प्रश्नपत्रिकेच्या शेकटी जोडलेल्या कोऱ्या मागावरच काचवे काम करावे.
- जर आपण ओ.एम.आर. वर तमूद केलेल्या ठिकाणा व्यतिरिक्त इतर कोठेही नाव, आसन क्रमांक, फोन नंबर किंवा ओळख पटले अशी कोणतीही खुण केलेली आढळून आल्यास अथवा अस्पष्ट भाषेचा वापर किंवा इतर गैरमागची अकलाब कोल्यास विद्यार्थ्यांना परीक्षेस आपण उतरविल्यास येईल.
- परीक्षा संपल्यानंतर विद्यार्थ्यांचे मूळ ओ.एम.आर. उत्तरपत्रिका पर्यवेक्षकांकडे परत करणे आवश्यक आहे. तथापि, प्रश्नपत्रिका व ओ.एम.आर. उत्तरपत्रिकेची द्वितीय प्रत आचल्याबरोबर नेण्यास विद्यार्थ्यांना परवानगी आहे.
- फक्त निरुपय किंवा काळजा बोल पेशाचा वापर करावा.
- कॉलकल्युलेटर किंवा लॉग टेबल वापरण्यास परवानगी नाही.
- चुकीच्या उत्तरासाठी गुण कपात केली जाणार नाही.

SEP - 32221/II—A

Physical Science Paper II

Time Allowed : 120 Minutes]

[Maximum Marks : 200

Note : This Paper contains **Hundred (100)** multiple choice questions. Each question carrying **Two (2)** marks. Attempt *All* questions.

- | | |
|--|--|
| <p>1. Consider a vector $\vec{v} = \frac{\vec{r}}{r^3}$. The surface integral of this vector over the surface of a cube of side a and centered at the origin is :</p> <p>(A) zero</p> <p>(B) 2π</p> <p>(C) $2\pi a^3$</p> <p>(D) 4π</p> <p>2. If a force \vec{F} is derivable from a potential function $V(r)$, where r is the distance from the origin of the coordinate system, it follows that :</p> <p>(A) $\vec{\nabla} \times \vec{F} = 0$</p> <p>(B) $\vec{\nabla} \cdot \vec{F} = 0$</p> <p>(C) $\vec{\nabla} V = 0$</p> <p>(D) $\nabla^2 V = 0$</p> | <p>3. A book contains 600 typographic errors in its 600 pages. These typographic errors occur completely at random. Using the Poisson distribution, the probability, that a page contains no error, is :</p> <p>(A) 0</p> <p>(B) 1</p> <p>(C) 0.37</p> <p>(D) 0.74</p> <p>4. For which of the following values of z, will the function $\omega = u + iv$ defined by $z = \sin u \cosh v + i \cos u \sinh v$ cease to be analytic ?</p> <p>(A) $z = +i$</p> <p>(B) $z = -i$</p> <p>(C) $z = 0$</p> <p>(D) $z = \pm 1$</p> <p>5. Consider a circle C in the z plane, $z - 2 = 5$, then $\oint_C \frac{dz}{z - 3}$ is equal to :</p> <p>(A) ∞</p> <p>(B) 0</p> <p>(C) 3</p> <p>(D) 5</p> |
|--|--|

6. The solution of the differential equation

$$(1 + x) \frac{d^2y}{dx^2} + x \frac{dy}{dx} - y(x) = 0 \text{ is :}$$

- (A) $Ax^2 + B$
 (B) $Ax + Be^{-x}$
 (C) $Ax + Be^x$
 (D) $Ax + Bx^2$

where A and B are constants.

7. For a differential equation

$$\frac{d^2y}{dx^2} - \frac{2dy}{dx} + y = 0,$$

one of the solutions is :

- (A) e^x
 (B) $\ln x$
 (C) e^{-x^2}
 (D) e

8. The eigen values of the matrix

$$\begin{bmatrix} 2 & 3 & 0 \\ 3 & 2 & 0 \\ 0 & 0 & 1 \end{bmatrix} \text{ are :}$$

- (A) 5, 2, -2
 (B) -5, -1, 1
 (C) 5, 1, -1
 (D) -5, 1, 1

9. The matrix $A = \frac{1}{\sqrt{3}} \begin{bmatrix} 1 & 1+i \\ 1-i & 1 \end{bmatrix}$

is :

- (A) Orthogonal
 (B) Symmetric
 (C) Antisymmetric
 (D) Unitary

10. Fourier series for the function

$$f(\theta) = \begin{cases} +1 & 0 < \theta < \pi \\ -1 & \pi < \theta < 2\pi \end{cases}, \text{ there are :}$$

- (A) even cosine terms only
 (B) both odd sine and cosine terms
 (C) sine terms only
 (D) odd sine terms only

11. A mass M moves with speed V. An explosion divides the mass in half giving each half a speed of v in the CM (Center of Mass) frame. The increase in the kinetic energy is LAB (Laboratory) frame is (the motion is confined in one dimension) :

- (A) $\frac{Mv^2}{2}$
 (B) $\frac{Mv^2}{4}$
 (C) $\frac{Mv^2}{\sqrt{2}}$
 (D) $\frac{Mv^2}{8}$

12. A 200 g mass is attached to one end of a spring ($k = 80 \text{ N/m}$). The mass is displaced from the equilibrium position by 0.05 m and released. It oscillates without friction about the mean position. The maximum speed of the mass is :
- (A) 10 m/s
 (B) 1 m/s
 (C) 0.1 m/s
 (D) 100 m/s
13. The conservation of angular momentum in central force field motion leads to :
- (A) Kepler's first law
 (B) Kepler's second law
 (C) Kepler's third law
 (D) None of the above
14. A particle of mass m moves under the action of a central force whose potential is $V(r) = Kmr^3$ ($K > 0$). If the particle describes circular orbit of radius a , then its energy should be :
- (A) $\frac{3}{2}mKa^3$
 (B) $\frac{3}{2}mKa^2$
 (C) $\frac{1}{2}mKa^2$
 (D) $\frac{1}{2}mKa^3$

15. The number of degrees of freedom for a system of two particles constrained to move on inner surface of a spherical balloon such that the separation between the particles remains fixed, is :
- (A) 5
 (B) 2
 (C) 4
 (D) 3
16. A pendulum consists of mass m and a massless stick of length l . The pendulum support oscillates horizontally with a position given by $x(t) = A \cos(\omega t)$. The Lagrangian of the system is :

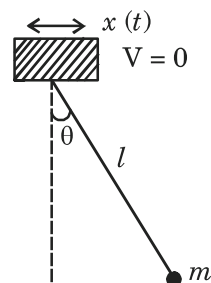

- (A) $\frac{1}{2}m(\dot{x}^2 + l^2 \dot{\theta}^2) + mgl \cos \theta$
- (B) $\frac{1}{2}m(\dot{x}^2 + l^2 \dot{\theta}^2 + 2l \dot{x} \dot{\theta} \cos \theta) + mgl \cos \theta$
- (C) $\frac{1}{2}m(\dot{x}^2 + l^2 \dot{\theta}^2 - 2l \dot{x} \dot{\theta} \cos \theta) + mgl \cos \theta$
- (D) $\frac{1}{2}m(\dot{x}^2 + l^2 \dot{\theta}^2 + 2l \dot{x} \dot{\theta} \sin^2 \theta) + mgl \cos \theta$

17. If the Lagrangian $L = L_0 + L_1 + L_2 + \dots + L_r + \dots$ where L_r is the homogeneous function of degree r in q_i , with coefficients as any function of q_i , then :
- (A) $H = L_1 + 2L_2 + 3L_3 + \dots$
 (B) $H = -L_0 - L_1 - 2L_2 - \dots$
 (C) $H = -L_0 + L_1 + 2L_2 + \dots$
 (D) $H = L_0 + L_1 + 2L_2 + \dots$
18. Consider a triatomic molecule schematically shown in the figure. The potential energy matrix V_{ij} is :

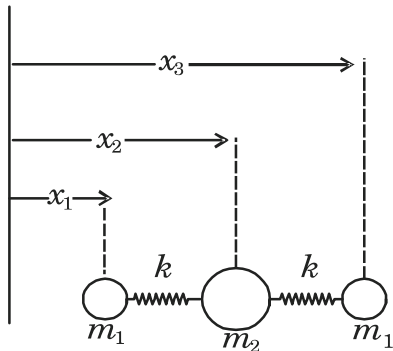

- (A) $\begin{pmatrix} 2k & 0 & k \\ 0 & k & -k \\ k & -k & k \end{pmatrix}$
- (B) $\begin{pmatrix} -k & k & 0 \\ k & 2k & 0 \\ 0 & 0 & 2k \end{pmatrix}$
- (C) $\begin{pmatrix} k & -k & 0 \\ -k & 2k & k \\ 0 & k & 2k \end{pmatrix}$
- (D) $\begin{pmatrix} k & -k & 0 \\ -k & 2k & -k \\ 0 & -k & k \end{pmatrix}$

19. A frame of reference S' is rotating with constant angular velocity ω with respect to a stationary frame of reference S . Both the frames of reference have common origin. The acceleration of vector \bar{A} in S' is :

- (A) $\frac{d^2 \bar{A}}{dt^2} = \frac{d'^2 \bar{A}}{dt^2} + 2\bar{\omega} \times \frac{d\bar{A}}{dt} + \bar{\omega} \times (\bar{\omega} \times \bar{A})$
- (B) $\frac{d^2 \bar{A}}{dt^2} = \frac{d'^2 \bar{A}}{dt^2} + \bar{\omega} \times \frac{d\bar{A}}{dt} + \bar{\omega} \times (\bar{\omega} \times \bar{A})$
- (C) $\frac{d^2 \bar{A}}{dt^2} = \frac{d'^2 \bar{A}}{dt^2} + \bar{\omega} \times \frac{d\bar{A}}{dt} - \bar{\omega} \times (\bar{\omega} \times \bar{A})$
- (D) $\frac{d^2 \bar{A}}{dt^2} = \frac{d'^2 \bar{A}}{dt^2} - 2\bar{\omega} \times \frac{d\bar{A}}{dt} - \bar{\omega} \times (\bar{\omega} \times \bar{A})$

20. If V_0 is the rest volume of a cube of side l_0 , then the volume viewed from a reference frame moving with velocity v in a direction parallel to an edge of cube is :

(A) $V_0 \left(1 - \frac{v^2}{c^2}\right)^{3/2}$

(B) $V_0 \left(1 - \frac{v^2}{c^2}\right)^{-3/2}$

(C) $V_0 \left(1 - \frac{v^2}{c^2}\right)^{1/2}$

(D) $V_0 \left(1 - \frac{v^2}{c^2}\right)^{-1/2}$

21. Two infinitely long line charges, each with uniform linear charge density λ are placed in the xz plane. One is placed along z -axis and the other is parallel to z -axis placed at $x = 4$. The Cartesian coordinates of the points A and B are A(6, -3, 0) and B(-2, 3, 0). The ratio of magnitudes of \vec{E} at point A to that at point B is

(A) 1

(B) 3

(C) $\frac{1}{3}$

(D) $\sqrt{\frac{13}{45}}$

22. A charged particle having charge q has linear momentum \vec{p} . It enters a region of uniform constant magnetic field \vec{B} with its velocity perpendicular to the field direction. The radius of a circular trajectory of the particle is given by :

(A) $\frac{B}{qp}$

(B) $\frac{p}{qB}$

(C) $\frac{qp}{B}$

(D) $\frac{qB}{p}$

23. A circular loop and a square loop have same perimeter. If same amount of current is flowing through each of them. The ratio of magnitudes of magnetic dipole moment of the circular loop to that of the square loop is

(A) $\frac{4}{\pi}$

(B) $\frac{\pi}{4}$

(C) 4π

(D) $\frac{1}{4\pi}$

24. A solid sphere of radius R , is uniformly charged with volume charge density ρ . The magnitude of the electric field outside the sphere at a distance r from the center is

- (A) $\frac{R^3 \rho}{3 \epsilon_0 r^2}$
- (B) $\frac{\rho R}{3 \epsilon_0}$
- (C) $\frac{\rho r}{3 \epsilon_0}$
- (D) $\frac{\rho}{\epsilon_0}$

25. The SI unit of the ratio of the magnitude of magnetic dipole moment to that of electric dipole moment is

- (A) m/s
- (B) s/m
- (C) C^2 ms
- (D) C^2 m/s

26. An interface divides the space into two regions. If there are no charges on the interface, then components of electric field \vec{E} are continuous across the interface.

- (A) Only tangential
- (B) Only normal
- (C) Both tangential and normal
- (D) None of the above

27. The electric and magnetic fields in the space are $\vec{E} = \hat{x} E_0 \cos(kz - \omega t)$ and $\vec{B} = \hat{y} B_0 \cos(kz - \omega t)$. The time averaged magnitude of Poynting vector in this region is

- (A) $\frac{E_0 B_0}{2\mu_0}$
- (B) $\frac{E_0 B_0}{\mu_0}$
- (C) $\mu_0 E_0 B_0$
- (D) $2\mu_0 E_0 B_0$

28. The vector potential $\vec{A}(\vec{r}, t)$ associated with electromagnetic wave, satisfies

- (A) $\nabla^2 \vec{A} = -\mu_0 \vec{J}$ in Lorentz gauge
- (B) $\nabla^2 \vec{A} - \frac{1}{c^2} \frac{\partial^2 \vec{A}}{\partial t^2} = -\mu_0 \vec{J}$ in Lorentz gauge
- (C) $\nabla^2 \vec{A} - \frac{1}{c^2} \frac{\partial^2 \vec{A}}{\partial t^2} = -\mu_0 \vec{J}$ in Coulomb gauge
- (D) $\nabla^2 \vec{A} - \frac{1}{c^2} \frac{\partial^2 \vec{A}}{\partial t^2} = \mu_0 \vec{J}$ in Coulomb gauge

29. A polarized rectangular dielectric slab of thickness $2d$ has $\bar{P} = P_0 \hat{z}$. If the slab is placed between $z = -d$ and $z = d$, then the volume bound charge density ρ_b and the surface bound charge density σ_b on the face $z = d$, are

- (A) $\rho_b = P_0 \quad \sigma_b = P_0$
- (B) $\rho_b = 0 \quad \sigma_b = P_0$
- (C) $\rho_b = P_0 \quad \sigma_b = 0$
- (D) $\rho_b = 0 \quad \sigma_b = 0$

30. A plane monochromatic electromagnetic wave is incident normally on air-glass interface. The refractive index of glass relative to air is 1.5. The fraction of incident energy that gets transmitted is

- (A) $\frac{1}{5}$
- (B) $\frac{4}{5}$
- (C) $\frac{1}{25}$
- (D) $\frac{24}{25}$

31. The de Broglie wavelength of material particles which are in thermal equilibrium at temperature T is (symbols have usual meaning) :

- (A) $\frac{h}{\sqrt{2mkT}}$
- (B) $\frac{h}{\sqrt{mkT}}$
- (C) $\frac{h}{\sqrt{mkT}}$
- (D) $\frac{h}{\sqrt{mkT}}$

32. The uncertainty relation applies to :

- (A) any pair of dynamical variables
- (B) a pair of dynamical variables, the operators corresponding to which do commute
- (C) a pair of dynamical variables, the operators corresponding to which do not commute
- (D) x and p_x only

33. The wave function for a quantum mechanical system at $t = 0$ is given

as $|\psi(0)\rangle = \frac{1}{\sqrt{2}}(|u_1\rangle + |u_2\rangle)$ where

$|u_1\rangle$ and $|u_2\rangle$ are eigen functions corresponding to energies E_1 and E_2 ($E_2 > E_1$). The shortest time after which $|\psi(t)\rangle$ will become orthogonal to $|\psi(0)\rangle$ is :

(A) $= -\frac{\hbar\pi}{2(E_2 - E_1)}$

(B) $\frac{\hbar\pi}{(E_2 - E_1)}$

(C) $\frac{\sqrt{2}\hbar\pi}{(E_2 - E_1)}$

(D) $\frac{2\hbar\pi}{(E_2 - E_1)}$

34. The wave function of a system is

given as $Ae^{ikr}\left(\frac{r_0}{r}\right)$ where A and r_0

are given constants. The probability current density at $r = r_0$ is :

(A) $\frac{A^2 \hbar k}{m}$

(B) $\frac{2A^2 \hbar k}{m}$

(C) $\frac{A^2 \hbar k}{2m}$

(D) $\frac{A^2 \hbar k}{4m}$

35. The wave function for a one-

dimensional harmonic oscillator is

given as $|\psi\rangle = b_1|0\rangle + b_2|1\rangle$

where $|0\rangle$ and $|1\rangle$ are the ground

and first excited state wave function.

The expectation value $\langle\psi|x|\psi\rangle$

will be minimum, when :

(A) $b_2 = b_1/\sqrt{2}$

(B) $b_1 = 1, b_2 = 0$

(C) $b_1 = b_2$

(D) $b_1 = 2b_2$

36. $\psi_{nlm}(\vec{r})$ denotes the eigen function

of the Hamiltonian with spherically

symmetric potential $V \equiv V(|\vec{r}|)$. A

general state $\bar{\psi}(\vec{r})$ of the system is

given as :

$$\bar{\psi}(\vec{r}) = \frac{1}{5}[3\psi_{211}(\vec{r}) + \psi_{210}(\vec{r}) - \sqrt{15}\psi_{21-1}(\vec{r})].$$

The expectation value of the operator

$L_x^2 + L_y^2$ in the state $\bar{\psi}(\vec{r})$ is :

(A) $13\hbar^2 / 25$

(B) $26\hbar^2 / 25$

(C) $2\hbar^2$

(D) $39\hbar^2 / 25$

37. A system described by the Hamiltonian matrix $H_0 = \begin{pmatrix} 1 & 0 \\ 0 & 1 \end{pmatrix}$

is perturbed by $H' = \begin{pmatrix} \delta & \delta \\ \delta & \delta \end{pmatrix}$ where

($\delta \ll 1$). The energy eigen values of the perturbed system within first order perturbation theory are :

- (A) $(1 + \delta)$ and $(1 - 2\delta)$
- (B) $(1 + \delta)$ and $(1 - \delta)$
- (C) $(1 + 2\delta)$ and $(1 - 2\delta)$
- (D) 1 and $(1 + 2\delta)$

38. Consider the wave function $\psi(x_1, x_2) = \psi(\vec{r}_1, \vec{r}_2) \chi(s_1, s_2)$ for a fermionic system consisting of two spin-half particles. The spatial part of the wave function is as given below :

$$\psi(\vec{r}_1, \vec{r}_2) = \frac{1}{\sqrt{2}} \left\{ \phi_1(\vec{r}_1) \phi_2(\vec{r}_2) + \phi_2(\vec{r}_1) \phi_1(\vec{r}_2) \right\}$$

where ϕ_1 and ϕ_2 are single particle states, other symbols have usual meaning. The spin part of the wave function is (α and β are spin up and down single particle states) :

- (A) $\frac{1}{\sqrt{2}} (\alpha\beta + \beta\alpha)$
- (B) $\frac{1}{\sqrt{2}} (\alpha\beta - \beta\alpha)$
- (C) $\alpha\alpha$
- (D) $\beta\beta$

39. A particle is scattered by a spherically symmetric potential. In the centre of mass frame the wave function of the incoming particle is $\psi = Ae^{ikr}$, where K is the wave vector and A is a constant. If $f(\theta)$ is an angular function, then in the asymptotic region the scattered wave function has the form :

- (A) $A f(\theta) e^{ikr}$
- (B) $A f(\theta) e^{-ikr}$
- (C) $\frac{A f(\theta) e^{ikr}}{r^2}$
- (D) $\frac{A f(\theta) e^{-ikr}}{r^2}$

40. A free particle of mass m moves along the x -axis. It is described by the wave function

$$\psi(x) = \frac{1}{(2\pi\alpha)^{1/4}} \exp \left[-\frac{x^2}{4\alpha^2} + ix \right]$$

($\alpha = \text{constant}$)

The expectation value of the momentum in this state is :

- (A) $\hbar\alpha$
- (B) $\hbar\sqrt{\alpha}$
- (C) \hbar/α
- (D) $\hbar/\sqrt{\alpha}$

41. Chemical potential and magnetic permeability are :
- (A) Both intensive variables
 (B) Both extensive variables
 (C) Intensive and extensive variables respectively
 (D) Extensive and intensive variables respectively
42. A spring has a spring constant K . A mass m is placed on the spring. In equilibrium the spring would extend by $\frac{mg}{K}$. The surroundings are at temp. T . If the system starts with initial expansion by an amount $\frac{mg}{2K}$ and after a long time comes to an equilibrium the increase in the entropy of the universe would be :
- (A) $\frac{m^2 g^2}{2KT}$
 (B) $\frac{m^2 g^2}{16KT}$
 (C) $\frac{3m^2 g^2}{4KT}$
 (D) $\frac{m^2 g^2}{8KT}$
43. One large system is at a temperature 300 K and another at 299 K. An amount of heat 10 J is taken from the hotter system and added to the colder system. The total entropy change of the two systems is about :
- (A) $1.1 \times 10^{-15} \text{ JK}^{-1}$
 (B) $1.1 \times 10^{-6} \text{ JK}^{-1}$
 (C) $1.1 \times 10^{-9} \text{ JK}^{-1}$
 (D) $1.1 \times 10^{-11} \text{ JK}^{-1}$
44. For certain system the number of accessible states is given by $\Omega = Ae^{r(VU)^{1/2}}$, where A and r are constants, V is volume and U is the internal energy. The temperature would be :
- (A) $T = \frac{2r(UV)^{\frac{1}{2}}}{K_B}$
 (B) $T = \frac{2r}{K_B} \cdot \left(\frac{U}{V}\right)$
 (C) $T = \frac{2U^{1/2}}{K_B \sqrt{V^{1/2}}}$
 (D) $T = \frac{r^2(UV)}{K_B}$

45. The magnitude of Fermi wave vector K_F for a two-dimensional system of N electrons in a square box of area A is :

(A) $K_F = \frac{2\pi N}{A}$

(B) $K_F = \sqrt{\frac{2\pi N}{A}}$

(C) $K_F = \frac{N}{A}$

(D) $K_F = \left(\frac{2\pi N}{A}\right)^2$

46. A system consists of two identical particles. Each particle can occupy only two energy levels : $E_1 = \varepsilon$ and $E_2 = 2\varepsilon$. If the particles satisfy Fermi-Dirac statistics, the partition

function would be $\left(\beta = \frac{1}{K_B \tau}\right)$:

(A) $z = e^{-2\beta\varepsilon} + e^{-3\beta\varepsilon} + e^{-4\beta\varepsilon}$

(B) $z = \frac{1}{2}(e^{-\beta\varepsilon} + e^{-2\beta\varepsilon})^2$

(C) $z = e^{-3\beta\varepsilon}$

(D) $z = 2(e^{-\beta\varepsilon} + e^{-2\beta\varepsilon})$

47. The number of distinct ways in which 4 indistinguishable bosons can be distributed in 7 energy levels, is :

(A) 4^7

(B) 210

(C) 7^4

(D) $\frac{7!}{4!3!}$

48. Assume that water has a constant heat capacity C over the range 273 K to 373 K. A certain amount of water at 273 K is brought into contact with a heat bath at 373 K. When the water has just thermalized with the bath, the change in entropy of the universe is :

(A) $C \left[\frac{-100}{373} + \ln\left(\frac{373}{273}\right) \right]$

(B) $-C \frac{100}{373}$

(C) $C \ln\left(\frac{373}{273}\right)$

(D) $C \ln\left(\frac{273}{373}\right)$

49. Consider n moles of an ideal gas. The heat transferred in an infinitesimal quasistatic process is :
- (A) $n (VdP - PdV)$
- (B) $n \left(\frac{C_V}{R} Vdp + \frac{C_P}{R} pdV \right)$
- (C) $n (VdP + PdV)$
- (D) $\frac{C_V}{nR} VdP + \frac{C_P}{nR} pdV$
50. For a van der Waals system at the critical point [the eq is $\left(p + \frac{a}{v^2} \right)(v - b) = RT$], the critical volume is :
- (A) $V_C = 3b$
- (B) $V_C = b$
- (C) $V_C = \frac{b^2}{a}$
- (D) $V_C = \frac{8}{27} \frac{b^2}{a}$
51. Floating voltage signals should be amplified by :
- (A) OP-AMP in inverting configuration
- (B) OP-AMP in non-inverting configuration
- (C) Instrumentation amplifier
- (D) Buffer amplifier
52. In a typical X-ray diffraction experiment the angles between source and detector is :
- (A) θ
- (B) 2θ
- (C) 3θ
- (D) 4θ
53. The resolving power of a Fabry-Perot etalon of 1 mm spacing and 0.92 reflectivity of each plate is :
- (A) 10^2
- (B) 10^3
- (C) 10^4
- (D) 10^5
54. Which of the following sources produces coherent light ?
- (A) CFL bulb
- (B) He-Ne laser
- (C) Tungsten filament bulb
- (D) Sodium lamp
55. Which of the following sensors is based on pyroelectric effect ?
- (A) Bolometer
- (B) Photomultiplier
- (C) Silicon based sensor
- (D) Lead titanate based sensor
56. The pump which is based on momentum transfer between the molecules is :
- (A) Diffusion pump
- (B) Cryopump
- (C) Rotary pump
- (D) Water pump

57. Short wavelength limit of 25 KeV X-ray tube is :
- (A) 50 \AA
 (B) 5 \AA
 (C) 0.5 \AA
 (D) 0.05 \AA
58. If the temperature of photomultiplier tube based detector at 200 K is elevated to 300 K (RT), keeping the other parameters constant, relative change in Johnson noise would be :
- (A) 2.25%
 (B) 50%
 (C) 22.5%
 (D) 5%
59. The resolving power of a plane diffraction grating depends on (N = no. of lines, n = order of diffraction) :
- (A) Nn
 (B) $1/Nn$
 (C) n/N
 (D) N/n
60. In X-ray powder diffraction pattern, the positions of the peak depend on :
- (A) Size of the crystal
 (B) Shape of the crystal
 (C) Texture
 (D) Lattice constant of the planes

61. In the following circuit, assume ideal diode for current calculation, but 0.7 across the diode for power calculation.

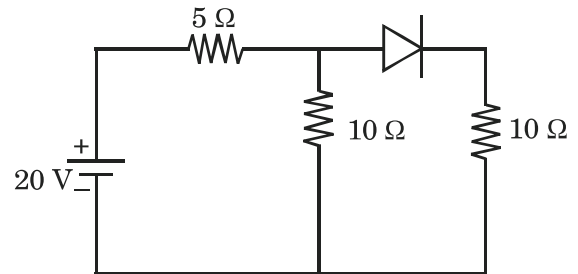

The minimum power rating of the diode should be :

- (A) 0.2 W
 (B) 0.4 W
 (C) 0.6 W
 (D) 0.8 W
62. As its name indicates, a unijunction transistor is identified as device having :
- (A) one p-n junction with three leads, ability to amplify signal and control a.c. power
 (B) two p-n junctions with three leads, ability to amplify signal but cannot control a.c. power
 (C) one p-n junction with two leads, ability to amplify signal and control a.c. power
 (D) one p-n junction with three leads, ability to control a.c. power but no ability to amplify signal

63. In the following Colpitts oscillator

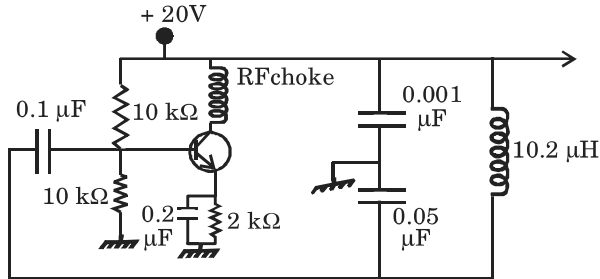

the frequency of oscillation is nearly :

- (A) 1.39 MHz
- (B) 1.59 MHz
- (C) 1.79 MHz
- (D) 2.99 MHz

64. In the following power supply circuit, the input of the transformer is connected to 50 V_{rms} a.c. supply.

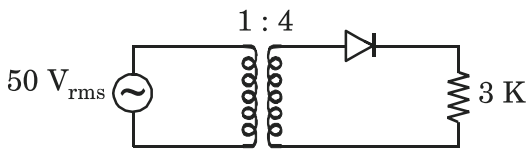

The transformer turn ratio is 1 : 4. Neglecting the voltage drop across the diode, the D.C. voltage across the load resistance 3K is nearly :

- (A) 200 Volt
- (B) 180 Volt
- (C) 90 Volt
- (D) 45 Volt

65. The input impedance of an amplifier shown in the following circuit is approximately equal to :
[Given : $Z_{in} = 2 \text{ M}\Omega$, $AOL = 2 \times 10^5$]

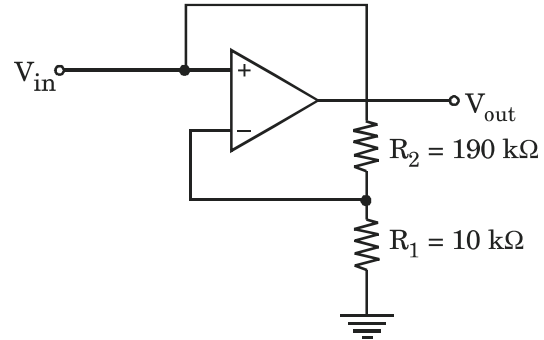

- (A) 20.0 GΩ
- (B) 10.0 GΩ
- (C) 20.0 MΩ
- (D) 10.0 MΩ

66. In the following amplifier circuit, the a.c. input signal V_{in} is of 2 mV.

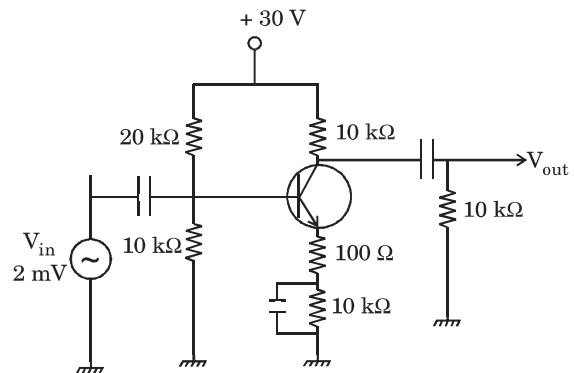

The output voltage, V_{out} is nearly :

- (A) 40 mV
- (B) 60 mV
- (C) 80 mV
- (D) 100 mV

67. The input to the following OP-AMP circuit is a sinusoidal voltage 5 mV and frequency 1 kHz. Find the output voltage :

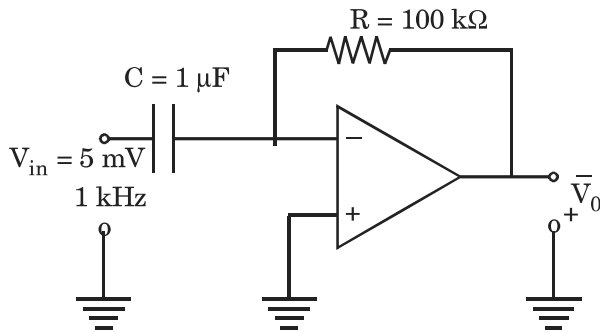

- (A) $1000 \pi \cos 2000 \pi t$ mV
 (B) $2000 \pi \cos 1000 \pi t$ mV
 (C) $2000 \pi \cos 2000 \pi t$ mV
 (D) $1000 \pi \cos 1000 \pi t$ mV
68. What is the identity of the following Boolean equation :
- (A + B) (A + C)
- (A) B + AC
 (B) B.A + C
 (C) A + BC
 (D) C.B + A
69. A Schottky diode made of metal-semiconductor junction is considered as :
- (A) Bipolar device with electrons as majority charge carriers
 (B) Unipolar device with holes as majority charge carriers
 (C) Bipolar device with holes as majority charge carriers
 (D) Unipolar device with electrons as majority charge carriers

70. A magnetron is used to provide microwave power over 2 GHz to 4 GHz frequency range. The frequency range can be designated as :

- (A) L Band
 (B) S Band
 (C) C Band
 (D) X Band

71. Orbital of hydrogen which is sixteen times away from the first orbit is :

- (A) Fifth orbit
 (B) Sixteenth orbit
 (C) Eighth orbit
 (D) Fourth orbit

72. Number of levels into which the electronic states of Na atom will split on account of anomalous Zeeman effect are grouped as :

- (A) $^2S_{1/2}$ into two, $^2P_{1/2}$ into two, $^2P_{3/2}$ into four
 (B) $^2S_{1/2}$ into two, $^2P_{1/2}$ into three, $^2P_{3/2}$ into three
 (C) $^2S_{1/2}$ into four, $^2P_{1/2}$ into two, $^2P_{3/2}$ into two
 (D) $^2S_{1/2}$ into three, $^2P_{1/2}$ into three, $^2P_{3/2}$ into three

73. Outer electron configuration of a divalent Nickel ion is $3d^6 4s^0$. The ground state of this ion is characterized by the spectroscopic term :
- (A) 5D
 (B) 5F
 (C) 2D
 (D) 4F
74. First Raman shifted line observed at 218 cm^{-1} for CCl_4 , excited by 632.8 nm of He-Ne laser, will correspond to scattered wavelength at (Given : $h = 6.6 \times 10^{-34} \text{ Js}$
 $c = 3 \times 10^8 \text{ m}$) :
- (A) 218.5 nm
 (B) 621.8 nm
 (C) 500.0 nm
 (D) 641.6 nm
75. A sample with $g = 2$ is placed in an Electron Spin Resonance (ESR) spectrometer operated at a magnetic field of $B_z = 0.33 \text{ T}$. What will be the frequency of resonance (Approximate) :
- (Given : $h = 6.6 \times 10^{-34} \text{ JS}$)
 (A) $9 \times 10^6 \text{ Hz}$
 (B) $9 \times 10^3 \text{ Hz}$
 (C) $9 \times 10^9 \text{ Hz}$
 (D) $9 \times 10^{14} \text{ Hz}$
76. The number of fundamental vibrational modes of H_2O molecule are :
- (A) 6
 (B) 4
 (C) 1
 (D) 3
77. A laser source emits radiation of 500 nm with a line width of 1 nm . The coherence length (l_c) is :
- (A) $100 \mu\text{m}$
 (B) 1 nm
 (C) $250 \mu\text{m}$
 (D) $2.5 \mu\text{m}$
78. The correct order of decreasing "first ionization potential" is :
- (A) Ra, Ba, Sr, Ca
 (B) Cs, Rb, K, Na
 (C) Na, Mg, Al, Si
 (D) C, B, Be, Li
79. The energy required to turn a magnetic dipole (moment μ_e) from parallel to antiparallel direction in magnetic field (B) is :
- (A) $-\mu_e B$
 (B) $+\mu_e B$
 (C) $\mu_e B/2$
 (D) $2\mu_e B$

80. Energy level diagram of Ne and that of He, for He–Ne laser is represented by and notations.
- (A) Russell-Saunders and Russell-Saunders notation
 (B) Paschen notation and Paschen notation
 (C) Russell-Saunders and Paschen notation
 (D) Paschen and Russell-Saunders notation
81. Which of the following is not a statement of the Bragg condition ?
- (A) $2 \sin \theta = n\lambda$
 (B) $\Delta \vec{K} = \vec{G}$
 (C) $2 \vec{K} \cdot \vec{G} = G^2$
 (D) $a_1 \cdot \Delta \vec{K} = 2\pi v_1$
82. An electron with a wave vector \vec{k} is incident on a square lattice of lattice constant a . If $k_x = k_y = \pm \pi/a$, the electron will be “Bragg reflected” by :
- (A) Lattice planes parallel to the x -axis only
 (B) Lattice planes parallel to the y -axis only
 (C) Lattice planes parallel to both x and y -axes
 (D) An infinite number of lattice planes aligned in any direction
83. Fermi energy for silver is 5.0 eV. At what temperature does the electronic contribution to specific heat for silver become identical with Dulong-Petit value ?
- (A) 1000 K
 (B) 800 K
 (C) 35.24×10^3 K
 (D) 3000 K
84. A dispersion relation between the angular frequency ω and the wave vector k for a one-dimensional periodic lattice is given by :
- $$\omega = (4C/M)^{1/2} \left| \sin \frac{1}{2} ka \right|,$$
- where a is the interatomic spacing, C is a force constant and M is mass. The group velocity at the edge of the zone, where $k = \pi/a$ is :
- (A) 0
 (B) 1
 (C) $\sqrt{ca^2 / 2}$
 (D) $\frac{1}{2} \sqrt{ca^2 / 2}$

85. If the ionization energy of potassium is 4.1 eV and electron affinity of Cl is 3.6 eV, the amount of energy in eV required to form a K^+ and Cl^- ion pair from a pair of K and Cl atoms is :
- (A) 2.0
(B) 1.5
(C) 1.0
(D) 0.5
86. The density of zinc is $7.13 \times 10^3 \text{ kg/m}^3$ and its atomic weight is 65.4. If the effective mass of the free electron in zinc is $0.85 M_e$, the Fermi energy in zinc is :
- (A) 3.50 eV
(B) 5.66 eV
(C) 2.00 eV
(D) 7.10 eV
87. Hall coefficient of 5 mm wide and 1 mm thick strip of InSb was found to be $4 \times 10^{-4} \text{ m}^3\text{C}^{-1}$. When it is placed in a magnetic field of 1T, Hall voltage was found to be 40.7 mV for 100 mA current passing along the sample. For the same amount of current if width is doubled and thickness is halved, then the Hall voltage will be :
- (A) 40.70 mV
(B) 20.35 mV
(C) 81.4 mV
(D) 10.17 mV
88. For a spherically symmetric dielectric medium (e.g. a medium with cubic structure), the local electric field on a dipole is given by : (P – Polarization, E – Microscopic average electric field, ϵ_0 – permittivity of the free space)
- (A) $E_{\text{loc}} = E + P/3\epsilon_0$
(B) $E_{\text{loc}} = P/3\epsilon_0$
(C) $E_{\text{loc}} = - P/3\epsilon_0$
(D) $E_{\text{loc}} = \text{zero}$
89. A paramagnetic salt contains 10^{28} ions/ m^3 with magnetic moment of one Bohr magneton. The magnetization produced in a uniform magnetic field of 10^6 A/m at room temperature (300 K) is :
- (A) 21 A/m
(B) 40 A/m
(C) 50 A/m
(D) 87 A/m

90. London penetration depth for a sample at 5 K and 7 K are 41.2 nm and 180.3 nm respectively. The superconducting transition temperature of the sample is :
- (A) 5.92 K
(B) 4.92 K
(C) 3.92 K
(D) 2.52 K
91. There are two nuclei X and Y. The Y nucleus has 20 protons and 25 neutrons. The nucleus X has 30 protons more and neutrons three times respectively as compared to that of Y nucleus. The radius of X nucleus is nearly equal to :
- (A) 4 Fermi
(B) 6 Fermi
(C) 8 Fermi
(D) 10 Fermi
92. Electrons of 400 MeV energy are made to fall on a target and scattered from nuclei which converted into diffraction pattern observed at an angle separation of $\theta = 20^\circ$. The charge distribution radius of the nuclei is nearly :
- (A) 4.32×10^{-15} m
(B) 6.50×10^{-15} m
(C) 8.88×10^{-15} m
(D) 10.44×10^{-15} m
93. The force which has range approaching infinity, interaction period $\sim 10^{-10}$ second and mediated by photon is :
- (A) Gravitational
(B) Strong
(C) Weak
(D) Electromagnetic
94. A nucleus decays by gamma-emission from the level $\frac{9^+}{2}$ to the level $\frac{1^-}{2}$. The gamma-ray decay mode can be classified as :
- (A) M1, E2
(B) M3, E4
(C) M4, E5
(D) M5, E6

95. The selection rules for the beta decay are governed by the :
- (A) Geiger-Nuttal relation
 - (B) Successive disintegration in radioactive isotopes rules
 - (C) Electromagnetic transition rules
 - (D) Fermi and Gamow-Teller transition rules
96. In case of high X or gamma radiation interaction, the cross-section for photoelectric effect is directly proportional to :
- (A) Z^5
 - (B) Z
 - (C) Z^2
 - (D) Z^3
97. An alpha particle having energy 5 MeV entering into the proportional counter with capacity of 25 pf. The resultant pulse height will be close to :
- (Ionisation Potential ~ 15 eV)
- (A) 4.3 mV
 - (B) 8.5 mV
 - (C) 2.1 mV
 - (D) 6.3 mV
98. A family of different nuclides is called isobaric family, when :
- (A) the atomic number is the same for all the nuclides
 - (B) the spin is the same for all the nuclides
 - (C) the mass number is the same for all the nuclides
 - (D) each nuclide undergoes beta-decay
99. The following nuclear reaction
- $$\pi^+ + n \rightarrow \overset{0}{\Lambda} + K^+$$
- (A) is not allowed due to non-conservation of baryon number
 - (B) is not allowed due to non-conservation of strangeness
 - (C) is not allowed due to non-conservation of isospin
 - (D) is allowed by all the applicable conservation laws
100. Based on the shell model, the estimated ground state spin of ${}^{15}_8\text{O}$ is :
- (A) 1/2
 - (B) 1
 - (C) 3/2
 - (D) 0

SEP - 32221/II—A

ROUGH WORK

SEP - 32221/II—A

ROUGH WORK